



# BEVERAGE-AIR

|                 |      |
|-----------------|------|
| Project: _____  | AIA# |
| Item: _____     |      |
| Location: _____ | SIS# |
| Approved: _____ |      |

**SPED48HC SANDWICH PREP: CUT TOP SERIES**

## FOOD PREPARATION TABLES

### SPED48HC Sandwich Prep Table With Drawers & 17" Cutting Board Hydrocarbon Series

**MODEL:  
SPED48HC-08C-4**



**5 Year Parts/Labor Warranty Available  
7 Year Compressor Warranty**

#### CABINET CONSTRUCTION

- Stainless steel front, sides, top, drawers and grille (galvanized back & bottom)
- Interior liner is made of corrosion resistant aluminum
- Full electronic control
- Cut top
- Airflow assures that product in open containers is kept below 41°F and above freezing
- Snap-in magnetic gaskets for positive drawer seal
- Painted aluminum drawer handles
- 17" Wide cutting board constructed of white polyethylene plastic
- Cutting board removable for cleaning
- Stainless steel drawer frames supported on telescoping drawer slides
- Drawer slides include locking mechanism that prevents drawers from being inadvertently pulled off cabinet
- Eight (8) 1/6 4" deep pans constructed of polycarbonate plastic
- Pans furnished are 4" deep constructed of polycarbonate plastic
- 6" Casters, with (2) brakes standard

#### OPTIONS & ACCESSORIES

- 3 Year parts/labor standard, additional 2 year warranty available
- Stainless steel back
- Stainless steel interior
- Clear lid
- Overshelves (single or double)
- Crumb catcher kit
- Richlite cutting board
- Night cover
- Bottle organizer
- Pan supports
- Pan support crossbar
- Pan configuration
- Locking divider
- 6" Legs or 3" casters
- Low profile casters
- Remote option\* (see note on back page)

#### REFRIGERATION SYSTEM

- Uses environmentally friendly, energy efficient R290 refrigerant, and meets all regulatory requirements for CARB, SNAP, DOE & more
- Adaptive defrost
- Epoxy coated evaporator coil
- Enhanced airflow maintains temperatures between 36° - 38°F



Please verify qualifying units by visiting:  
[www.energystar.gov/cfs](http://www.energystar.gov/cfs)

3779 Champion Blvd., Winston-Salem, NC 27105  
1-888-845-9800 Fax: 1-336-245-6453  
Beverage-Air.com Sales@bevair.com



# BEVERAGE-AIR

| MODEL                            | SPED48HC-08C-4  |
|----------------------------------|---|
| <b>EXTERNAL DIMENSIONAL DATA</b> |   |
| Width Overall                    | 48"   |
| Depth Overall                    | 38 <sup>3</sup> / <sub>8</sub> "  |
| Height Overall with Casters      | 45 <sup>1</sup> / <sub>4</sub> "  |
| No. of Drawers                   | 4   |
| Depth with Drawer Open Extended  | 47 <sup>7</sup> / <sub>8</sub> "  |
| Drawer Openings                  | 19 <sup>5</sup> / <sub>8</sub> " x 11 <sup>1</sup> / <sub>4</sub> "<br>19 <sup>5</sup> / <sub>8</sub> " x 7 <sup>1</sup> / <sub>2</sub> " |
| Width, Cutting Board             | 17"   |
| <b>INTERNAL DIMENSIONAL DATA</b> |   |
| NET Capacity (cubic ft.)         | 13.01   |
| Internal Width Overall (in)      | 44"   |
| Internal Depth Overall (in)      | 15 <sup>3</sup> / <sub>8</sub> "  |
| Internal Height Overall (in)     | 23"   |
| No. of Pans                      | 8   |
| <b>ELECTRICAL DATA</b>           |   |
| Full Load Amperes                | 2.0   |
| <b>REFRIGERATION DATA</b>        |   |
| Horsepower                       | 1/6   |
| Capacity (BTU/Hr)                | 1094  |
| Heat Rejection (BTU/Hr)          | 1641  |
| Charge (lbs/grams)               | 0.244/110   |
| <b>SHIPPING DATA</b>             |   |
| Gross Weight - Crated            | 358 lbs   |
| Height - Crated                  | 46"   |
| Width - Crated                   | 51"   |
| Depth - Crated                   | 33"   |

\*NOTE: Remote units are field wired and come with 6" legs. Refrigerant must be specified at time of order.

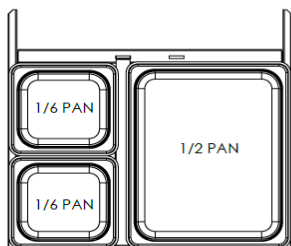

## Food Preparation Table: Cut Top Model: SPED48HC-08C-4

### Model Views

Required Clearance: 3" bottom & 2" rear

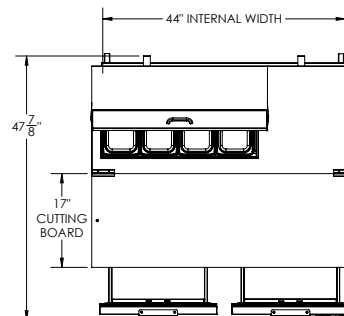

### PLAN VIEW

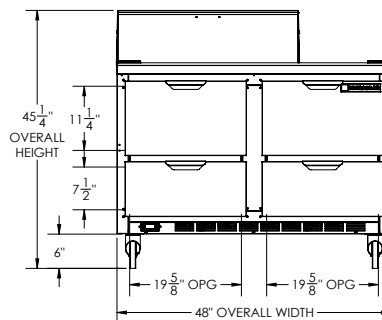

### ELEVATION VIEW

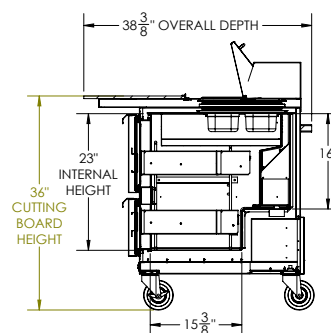

### SIDE VIEW



### ELECTRICAL CONNECTION

115/60/1  
NEMA 5-15P

Unit pre-wired at factory and include 8' long cord and plug set.